

To. :

DATE : 20 . . .

RoHS 1,3	Halogen Free
----------	--------------

SPECIFICATION

PRODUCT : STARCAP
MODEL : DMS3R3224RF

WRITTEN	CHECKED	APPROVED

KORCHIP CORP.

KORCHIP B/D, 359, Manan-ro, Manan-gu, Anyang-si, Gyeonggi-do, KOREA

TEL : 82 - 31 - 361 - 8000

FAX : 82 - 31 - 361 - 8080

Index

Page No.	ITEM	etc.
1	Cover Page	
2	Index	
3	Revision History	
4	1. Scope	
	2. Part Number System	
	3. Photo	
	4. General Specifications	
5	5. Cell Structure	
6	6. Appearance and Dimensions	
7	7. Reliability Specifications	
8-10	8. Packing Specifications	
11	9. Labeling Standards	
12	10. Measuring Method of Characteristics	
13	11. Mounting	
14-15	12. Cautions for Use	
16	13. Environmental Management	

1. Scope

This specification applies to STARCAP(Electric Double Layer Capacitor), submitted to specified customer in cover page.

2. Part Number System

<u>DMS</u>	<u>3R3</u>	<u>224</u>	<u>RF</u>
①	②	③	④

- ① Series Name : DMS
- ② Rated Voltage : 3.3VDC
- ③ Capacitance : 0.22 F (224 = 22 × 10⁺⁴ uF)
- ④ Special Code

3. Photo



4. General Specifications

ITEMS	VALUE
Rated Voltage	3.3 VDC
Operating Temp.	-10 ~ +60 °C
Capacitance (F)	0.22 F
Capacitance Tolerance	-20 ~ 80 %
Equivalent Series Resistance (ESR)	Less than 200Ω

5. Cell Structure

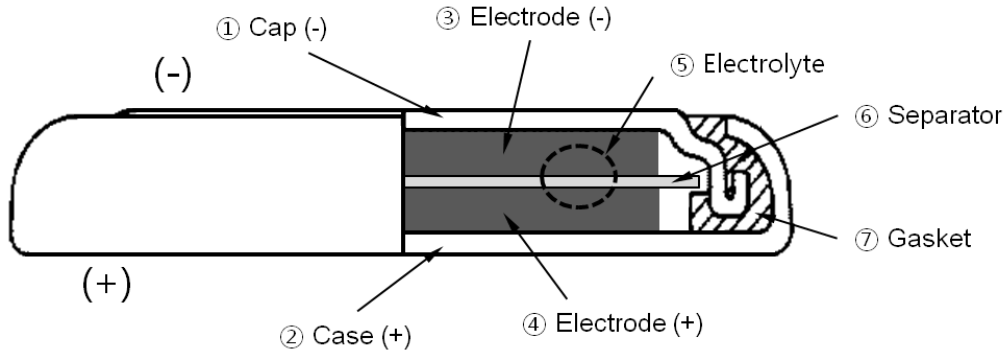

Part Name	Material
① Cap (-)	Stainless Steel
② Case (+)	Stainless Steel
③ Electrode (-)	Activated Carbon
④ Electrode (+)	Activated Carbon
⑤ Electrolyte	Organic Electrolyte
⑥ Separator	Polypropylene
⑦ Gasket	Engineering Plastic

6. Appearance and Dimensions

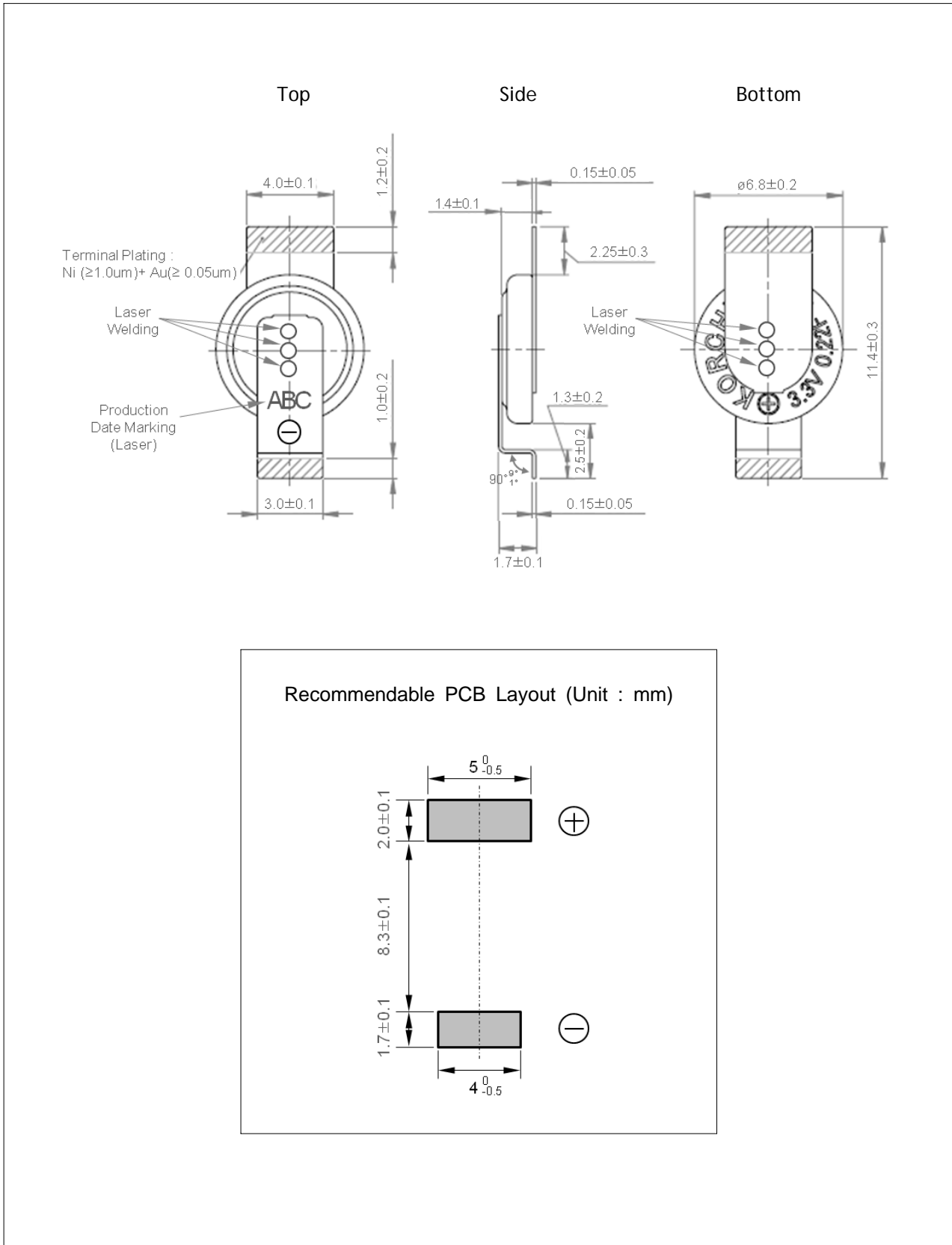

7. Reliability Specifications

Item		Specification		Test Condition													
Temperature Characteristics	Capacitance Change	Step 2	Within $\pm 30\%$ of Initial Value	Measure electrical characteristics after exposing STARCAP Capacitor to each temperature atmosphere for one(1) hour <table border="1" style="margin-left: auto; margin-right: auto;"> <thead> <tr> <th>Step</th> <th>Temperature</th> </tr> </thead> <tbody> <tr> <td>1</td> <td>20\pm2$^{\circ}$C</td> </tr> <tr> <td>2</td> <td>-10\pm2$^{\circ}$C</td> </tr> <tr> <td>3</td> <td>20\pm2$^{\circ}$C</td> </tr> <tr> <td>4</td> <td>60\pm2$^{\circ}$C</td> </tr> <tr> <td>5</td> <td>20\pm2$^{\circ}$C</td> </tr> </tbody> </table>		Step	Temperature	1	20 \pm 2 $^{\circ}$ C	2	-10 \pm 2 $^{\circ}$ C	3	20 \pm 2 $^{\circ}$ C	4	60 \pm 2 $^{\circ}$ C	5	20 \pm 2 $^{\circ}$ C
	Step		Temperature														
	1	20 \pm 2 $^{\circ}$ C															
	2	-10 \pm 2 $^{\circ}$ C															
	3	20 \pm 2 $^{\circ}$ C															
	4	60 \pm 2 $^{\circ}$ C															
5	20 \pm 2 $^{\circ}$ C																
ESR	5Times or less than Initial Value																
Capacitance Change	Step 4	Within $\pm 30\%$ of Initial Value															
ESR		200 Ω or less															
Capacitance Change	Step 5	Within $\pm 10\%$ of Initial Value															
ESR Change		200 Ω or less															
Reflow Soldering Effect	Capacitance	Spec. Value	Pb-Free Reflow Solder Peak Temp. : 260 \pm 5 $^{\circ}$ C Duration at Peak Temp. : 5 \pm 0.5 $^{\circ}$ C														
	Appearance	No Marked Defect															
Humidity Resistance	Capacitance Change	$\pm 30\%$ of Initial Value	Temp. : 40 \pm 2 $^{\circ}$ C Humidity : 90 ~ 95%RH Time : 500 \pm 8 Hours No Voltage Applied														
	ESR	2K Ω or less															
	Appearance	No Marked Defect															
Self Discharge Characteristics	Voltage	More than 1.8Vdc	Charging Condition	Voltage : 3.3Vdc Current : 20mA Charge Time : 24 Hours													
			Self Discharge Condition	Duration : 24 Hours Temp. : Less than 25 $^{\circ}$ C Humidity : Less than 70%RH													
Vibration Resistance	Capacitance	Spec. Value	Amplitude : 1.5mm Frequency : 10 ~ 55Hz Direction : X, Y, Z 3 Directions Test Time : 6 Hours														
	ESR	Spec. Value															
	Appearance	No Marked Defect															
Terminal Strength	Appearance	Terminals shall not be separated	Load 10N , 10 \pm 1 Sec.														
Terminal Bend Strength			Load 5N , Angle 90 $^{\circ}$, 1Cycle														
Endurance	Capacitance Change	Within $\pm 30\%$ of Initial Value	Temp. : 60 \pm 2 $^{\circ}$ C Test Time : 1,000(+24,-0) Hours Applied Voltage : 3.3Vdc														
	ESR	2K Ω or less															
	Appearance	No Marked Defect															
Shelf Life	Capacitance Change	Within $\pm 30\%$ of Initial Value	Temp. : 60 \pm 2 $^{\circ}$ C Test Time : 1,000(+24,-0) Hours No Voltage Applied														
	ESR	2K Ω or less															
	Appearance	No Marked Defect															

8. Packing Specifications

1) Carrier Tape

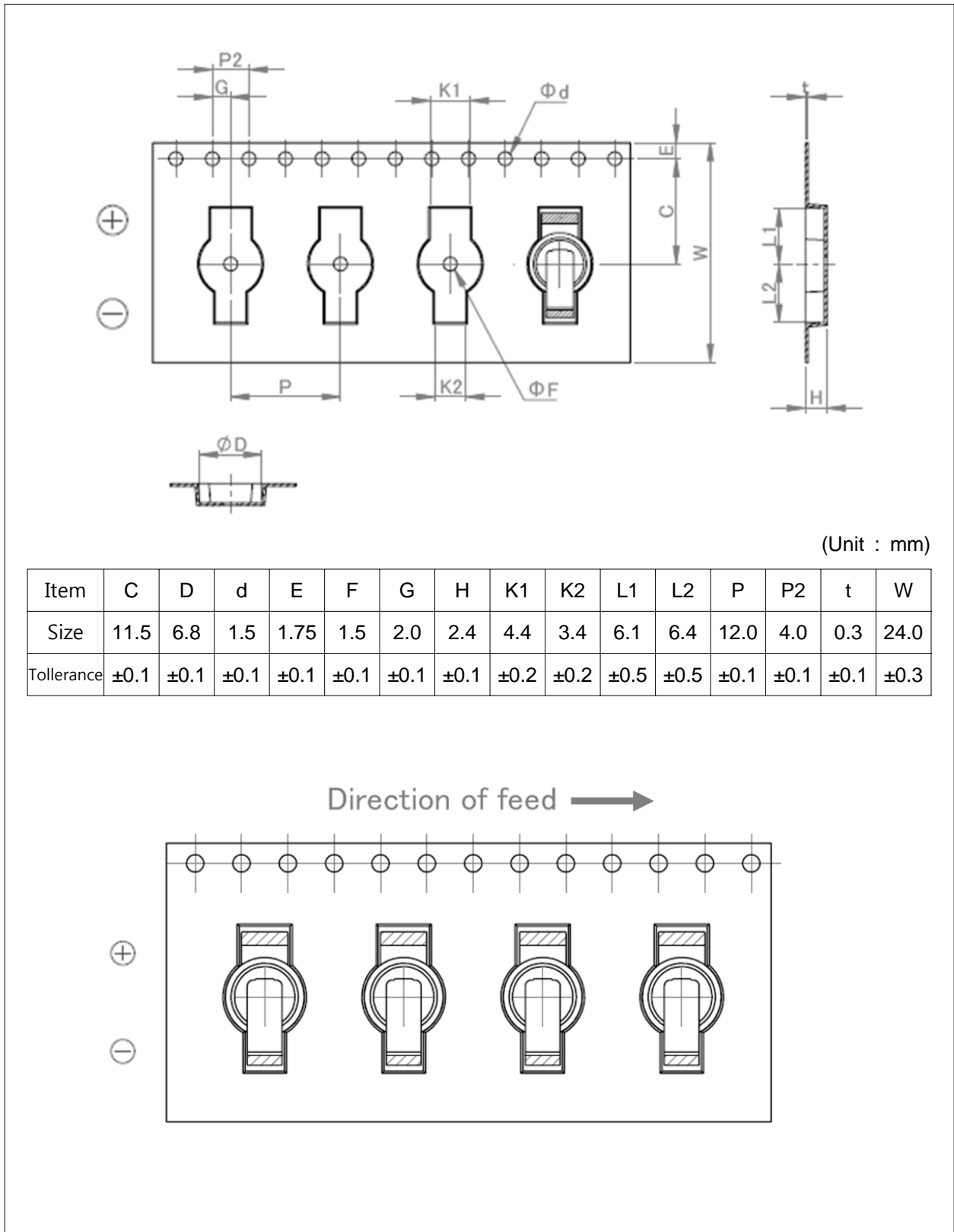

2) Reel

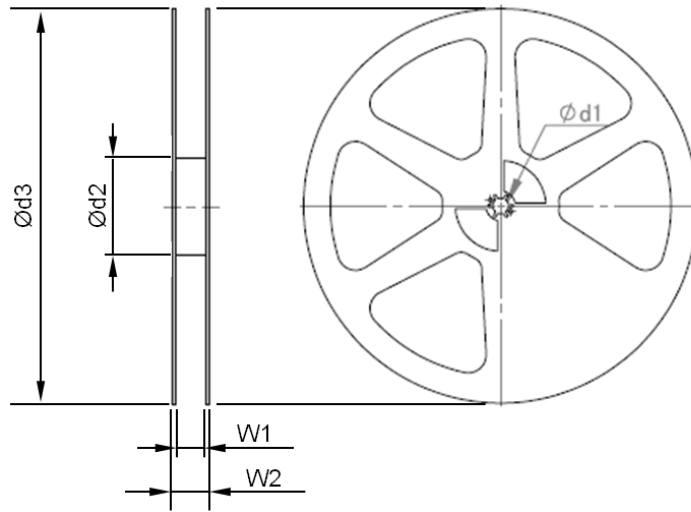

(Unit : mm)

W1	W2	Ød1	Ød2	Ød3
25±0.5	(29.5±1)	13±0.5	80±1	330±1 (13inch)

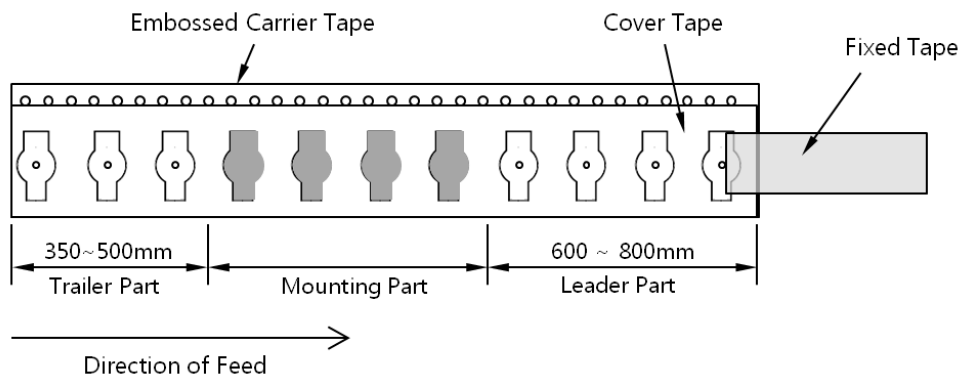
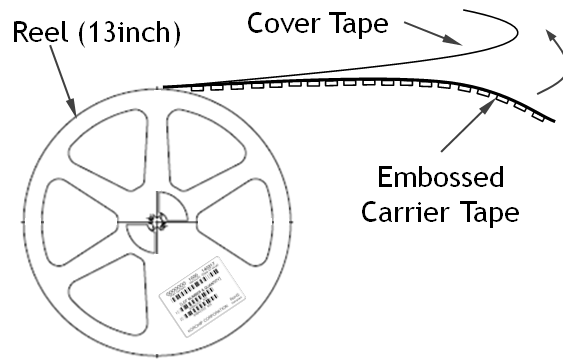

3) Box

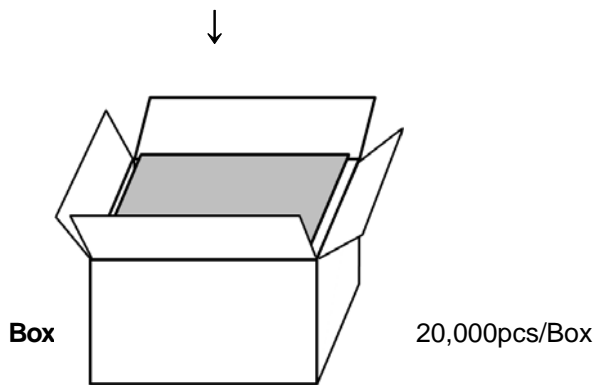
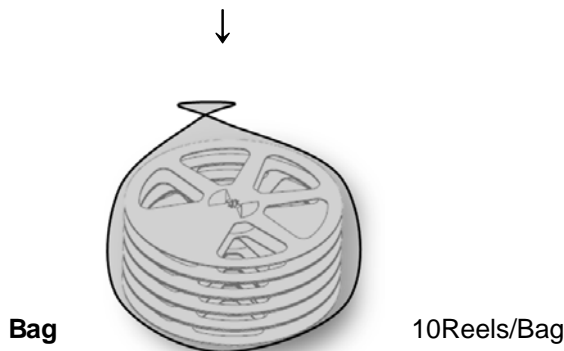
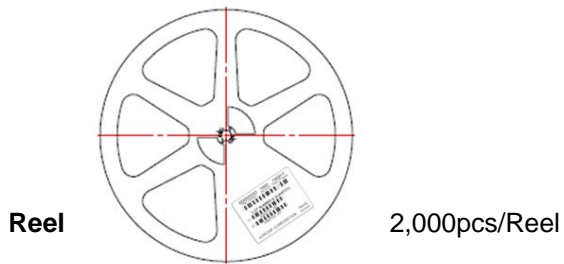

	Unit	Reel	Bag	Box
Weight	0.22g	0.90kg	9.0kg	10kg
Qty. (pcs)	1	2,000	20,000	20,000

<Weight Information>

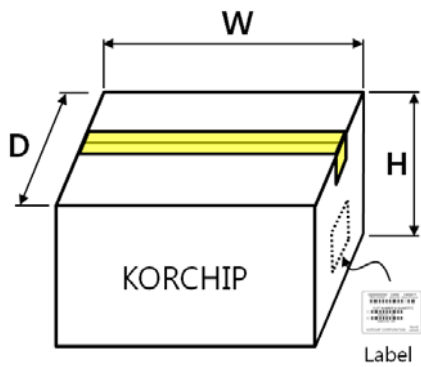

W	D	H
350mm	350mm	370mm

<Box Dimension>

9. Labeling Standards

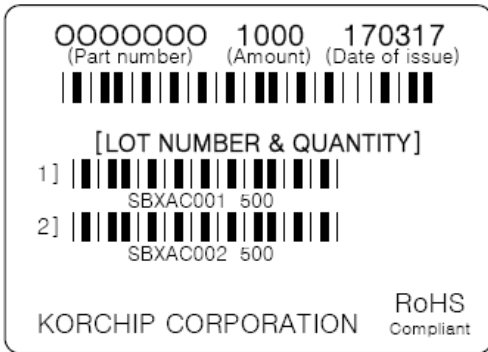

← (Example)

Lot No. System

Ex.) S E X A C 002
 ① ② ③ ④ ⑤ ⑥

- ① Product Code : S (STARCAP)
- ② Production Year Code : A (2016), B (2017), C (2018), D (2019), E (2020)...
- ③ Factory Identification Code : X (Factory X)
- ④ Production Month Code : A (Jan.), B (Feb.), ... , J (Oct.), K (Nov.), L (Dec.)
- ⑤ Production Date Code : 1 (1st), 2 (2nd), ... , 9 (9th), A (10th), B (11th), C (12th) ...
 Q (26th), R (27th), S (28th), ... , V (31th)
- ⑥ Lot Issuing Serial Code : 001 (First lot of a specific day), 002 (Second lot of a specific day), 003 (Third lot of a specific day)...

10. Measuring Method of Characteristics

<p>Capacitance</p>	<ol style="list-style-type: none"> 1) Charge the STARCAP with constant current $I_{charge}(=1 \pm 0.1mA)$ to $V_{charge}(=3.3V)$ then keep charging for $T_{charge}(=3000sec.)$ 2) Discharge the STARCAP with constant current $I_{disch}(=0.5mA)$ while measure the discharge time T_1, T_2 between $V_1(=2.64V)$ and $V_2(=1.32V)$. 3) Calculate capacitance using the following formula. <div style="text-align: center;"> </div> $C = \frac{I_{disch} \times (T_1 - T_2)}{V_1 - V_2}$
<p>Equivalent Series Resistance (ESR @1kHz)</p>	<ul style="list-style-type: none"> ● Measure ESR by the LCR meter. (Frequency:1kHz, Bias Voltage : $0^{+0.05}V$) or ● Calculate ESR using the following formula. <div style="display: flex; align-items: center;"> <div style="flex: 1;"> <p style="text-align: center;">$ESR[\Omega] = V / i$</p> </div> <div style="flex: 2;"> <p>$R[\Omega] = V[V] / I[A] \quad * \quad i[mA] = I[A] \times 10^{-3}$</p> <p>R : Internal resistance(ESR) [Ω]</p> <p>V : Measured voltage between terminals [V]</p> <p>i : Current 1mA(A.C.)</p> </div> </div>
<p>☞ The STARCAP should be shorted before each measurement as follows ; Capacitance : 60 min. , ESR : 15 min. , LC : 15 min.</p>	

11. Mounting

1) Reflow Soldering

Excessive heat stress may result in the deterioration of the electrical characteristics of the capacitor and electrolyte leakage due to the rise in internal pressure.

Use the general reference chart then set soldering temperature and time.

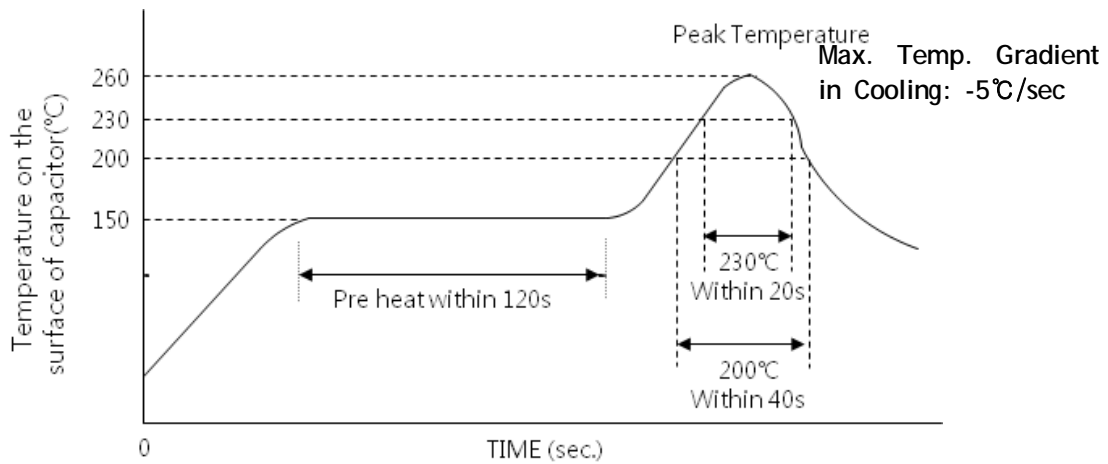

The time of repeated reflow soldering must be two times or less.

Do not use reflow soldering when the cell voltage is above 0.3V.

2) Manual Soldering

For use of a soldering iron, it should not touch the cell body.

Temperature of the soldering iron should be less than 360°C.

Soldering time for terminals should be less than 3(-0/+1) seconds.

12. Cautions for Use

Please be careful for following points when you use Korchip's EDLC.

1) Do not apply more than rated voltage.

If you apply more than rated voltage, electrolyte in EDLC will be decomposed and its ESR increase. At the worst, it may be broken.

2) Do not use EDLC for ripple absorption.

3) Polarity

Please mount it in accordance with its polarity.

4) Operating environment and lifetime

EDLC shows faster deterioration in high temperature operation. The lifetime of EDLC follows the general lifetime acceleration rule of double or half per every 10°C of ambient temperature decrease or increase respectively. A large temperature difference in one day or humid operating environment results in dew condensation on the surface of EDLC and it may cause fast deterioration or electrolyte leakage of EDLC.

If the EDLC is used in an electronic or electrical device over a long period of time especially in high temperature or high humidity environment, please check it periodically and replace it when necessary.

5) Cleaning

Some detergent or high temperature drying causes deterioration of EDLC. If you wash EDLCs, Consult us.

6) Following figure shows the general back-up circuit.

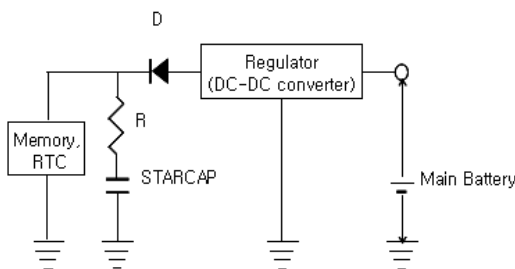

D : Diode to prevent the reverse current
 R : Resistor to control the charging current

7) Short-circuit

DO NOT short-circuit between terminals of EDLCs without resistor.

8) Storage

In long term storage, please store EDLCs in following condition;

- ① TEMP. : 15 ~ 35 °C
- ② HUMIDITY : Less than 60%RH
- ③ Non-dust, non-acidic and/or non-alkaline atmosphere
- ④ Avoid direct sun light, strong magnetic field

Storage period limit is one(1) year when an EDLC is stored in the above condition. Storage in improper condition may cause some damage on terminal surface or on outer tube of the EDLC.

9) Do not disassemble the EDLC. It contains electrolyte.

10) Series connection of EDLCs

Over-rated voltage may be applied to a single EDLC in series connection due to the deviation of capacitance and ESR of each EDLC. Please inform us if you are using EDLCs in series connection and please design so as not to apply over-rated voltage to each EDLC, and use EDLCs from a same lot.

11) The tips or edges of an EDLC terminals are very sharp. Please handle with care.

12) Industrial Application

Some industrial applications require a very high level of reliability to its parts including EDLCs. Therefore if the EDLC is to be used in an industrial application such as factory machinery, heavy electricity, etc. periodic inspection of EDLC is necessary. If there found any problem with the EDLC, please replace it.

13. Environmental Management

All STARCAP products are RoHS 1 and 3 compliant, Halogen Free and environment friendly.

Series	RoHS 1 directive (Pb, Cr+6, Hg, Cd, PBB, PBDE)	ELV directive (Pb, Cr+6, Hg, Cd)	PVC	Halogen Flame Retardant Free (Cl, Br)	RoHS 3 directive (DEHP, BBP, DBP, DIBP)	etc.
DMS	N.D.	N.D.	N.D.	N.D.	N.D.	

* N.D. : Not Detected or Within Permitted Range